

AIS200-3514

14 Volt CDI
Switch Unit

Installation Manual

PMA Approved

PMA# PQ894SW

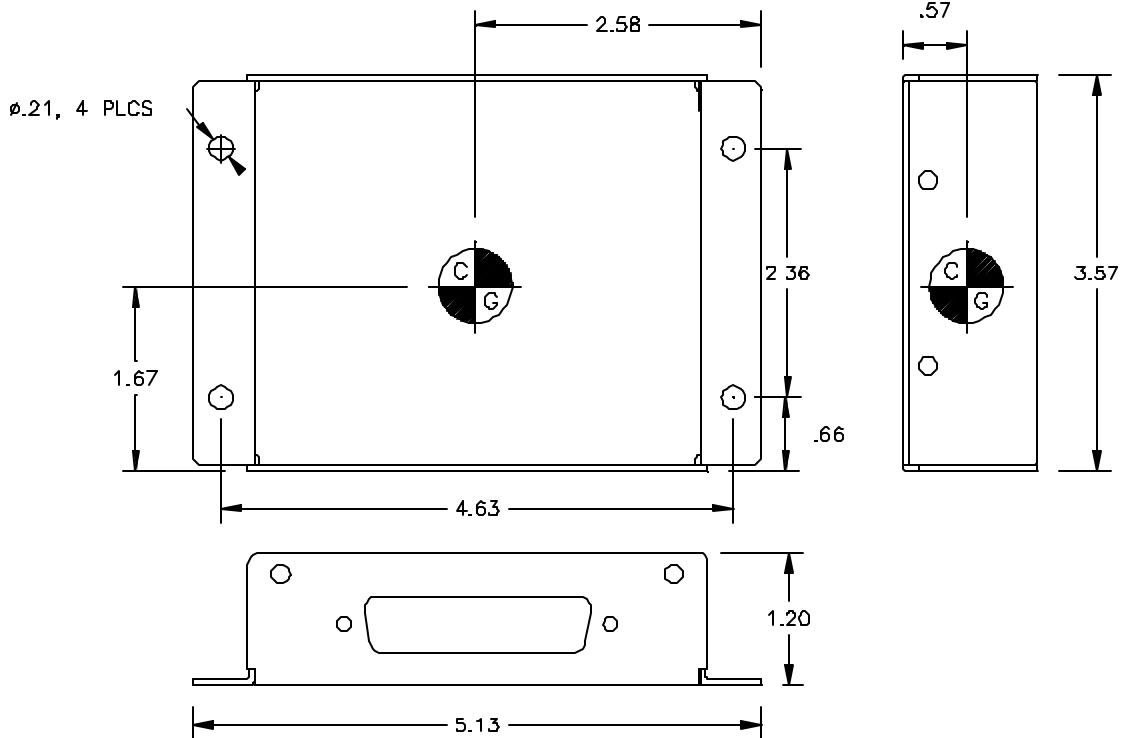

	<u>Size</u>
Length	5.15"
Width	3.46"
Height	1.20"

DO-160C Env. Cat.
[A1D1]-CA(MN)XXXXXXZBABATZXXX
Weight .45 LBS.

<u>Electrical</u>		<u>Environmental</u>	
Operating Voltage	14 VDC	Max. Operating Temp.	-20°C to +55°C
Operating Current	240mA (all relays engaged)	Max. Operating Altitude	50,000 Ft.
Contact Switching Rating*	1.0A @ 30VDC Max.	*Limited by circuit board track current capacity.	

Always use the Installation Manual provided. Do not rely on previously issued manuals.

Mating Connector and Contact Information

Description	Manufacturer	Manu. Part Number	SANDIA Part Number
Connector Housing	AMP/Tyco	204508-1	204508-1
Crimp Contact	AMP/Tyco	204351-1	305070
Hand Crimper Tool	AMP/Tyco	**601966-1	NA
Insertion/Extraction Tool	AMP/Tyco	**91067-1	NA

**Or Equivalent Tool

